

Aquarius



LUCROS
EVAPORATION SYSTEMS



Aquarius



Construction

The Lucros Aquarius Evaporation System is manufactured with brushed 304 Stainless steel brushed exterior and 316 Stainless Steel for the inner tank. Both are mig welded for strength and rigidity. The Aquarius model also has a 316 Stainless Steel plate covering and protecting the heater elements. A stainless steel fan and stack are also fitted as standard.

Operation

Operating the Aquarius unit is a very simple process. After filling the tank to the maximum fill level, push the start button on the control panel to begin heating the wastewater.

After two hours the extraction fan will automatically start to draw the steam generated through the exhaust stack.

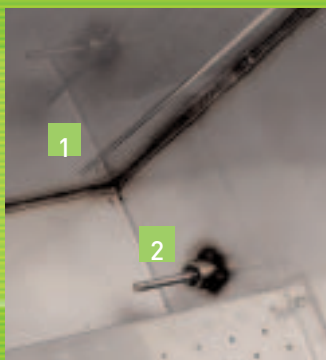

Safety Features

The Aquarius has two safety shutdown systems as standard to ensure safe operation. A low level resistance probe (1) automatically switches the unit off once the fluid falls below a designated height.

The secondary shutdown feature is a thermostat sensor probe (2) that continually measures the temperature of the fluid to ensure it does not exceed 100°C.

Technical Specification

Power Supply:

415 Volt, 3 Phase, 25 amp

Heating Elements:

3 x 5KW SS

Minimum Evaporation Rate:

20 litres per hour

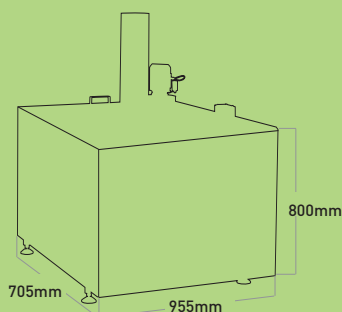

Design

The Aquarius evaporator is a low level design with a cover capable of opening to 90 degrees. This enables easy access with minimal maintenance time required to clean out waste sludge and oil residue from the system after use.

LUCROS LTD

UNIT 4 WHITEHALL TRADING ESTATE GERRISH AVENUE BRISTOL BS5 9DF
T. 0117 935 0064 F. 0117 9413848 E. sales@lucros.co.uk www.lucros.co.uk